

**Pilot's Operating Handbook and
FAA Approved Airplane Flight Manual
Supplement
for**

G3 Wing

When the G3 Wing is installed on the Cirrus Design SR22 serials 2334, 2420, 2438 and subsequent, this POH Supplement is applicable and must be inserted in the Supplements Section (Section 9) of the Cirrus Design SR22 Pilot's Operating Handbook. This document must be carried in the airplane at all times. Information in this supplement adds to, supersedes, or deletes information in the basic SR22 Pilot's Operating Handbook.

FAA Approved



Date Mar 26 2007

for Royace H. Prather, Manager
Chicago Aircraft Certification Office, ACE-115C
Federal Aviation Administration

Intentionally Left Blank

Section 1 - General

The G3 Wing is constructed in a conventional spar, rib, and shear section arrangement. The upper and lower skins are bonded to the spar, ribs, and aft shear web forming a torsion box that carries all of the wing bending and torsion loads. The rear shear webs are similar in construction but do not carry through the fuselage. The main spar is laminated epoxy/carbon fiber in a C-section, and is continuous from wing tip to wing tip. The wing spar passes under the fuselage below the two front seats and is attached to the fuselage in two locations. Lift and landing loads are carried by the single carry-through spar, plus a pair of rear shear webs (one on each wing) attached to the fuselage.

G3 Wing geometry is slightly changed with an 1° increase in dihedral which allows for the elimination of the aileron-rudder interconnect system.

The CG Envelope (Center of Gravity Envelope) is expanded to allow for slightly more forward loading at higher gross weights.

The main landing gear is moved slightly inboard and the strut angle increased to achieve an increase in airplane height of 1.5 inches.

The ice protection system's glycol tank is moved from the fuselage to an integral tank on the left wing and the porous panels are lengthened to cover the entire leading edge of the wing.

Other G3 Wing updates include:

- Increased fuel capacity,
- wing tip with integral, leading edge recognition lights.
- relocation of the fresh air inlets to the engine cowl and related environmental system changes,
- improved trailing edge aerodynamics
- improved wing root fairings,
- relocation of the stall warning port.

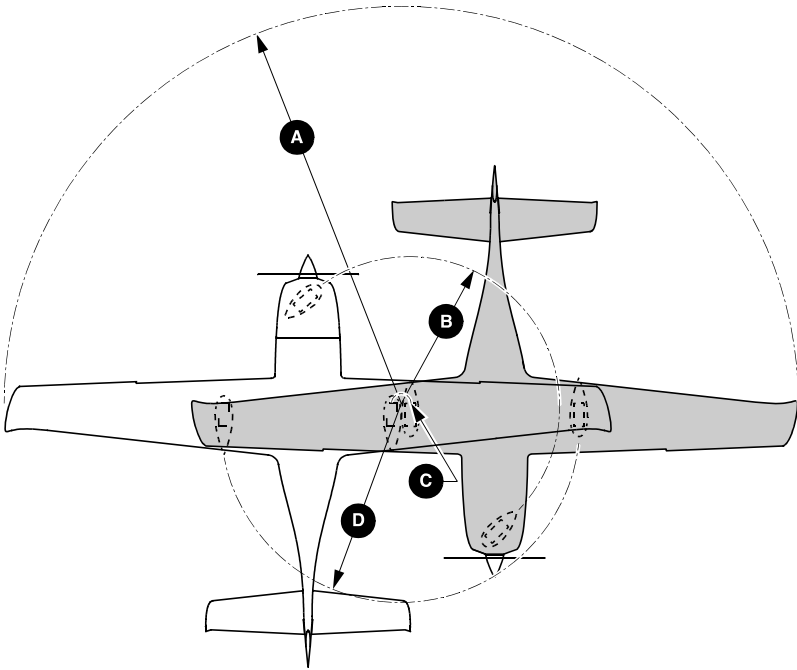

GROUND TURNING CLEARANCE

- A** RADIUS FOR WING TIP ----- 24.3 ft. (7.41 m)
- B** RADIUS FOR NOSE GEAR ----- 7.0 ft. (2.16 m)
- C** RADIUS FOR INSIDE GEAR ----- 0.5 ft. (0.15 m)
- D** RADIUS FOR OUTSIDE GEAR ----- 9.1 ft. (2.77 m)

TURNING RADII ARE CALCULATED USING ONE BRAKE AND PARTIAL POWER. ACTUAL TURNING RADIUS MAY VARY AS MUCH AS THREE FEET.

SR22_FM01_2412

Figure - 1
Turning Radius

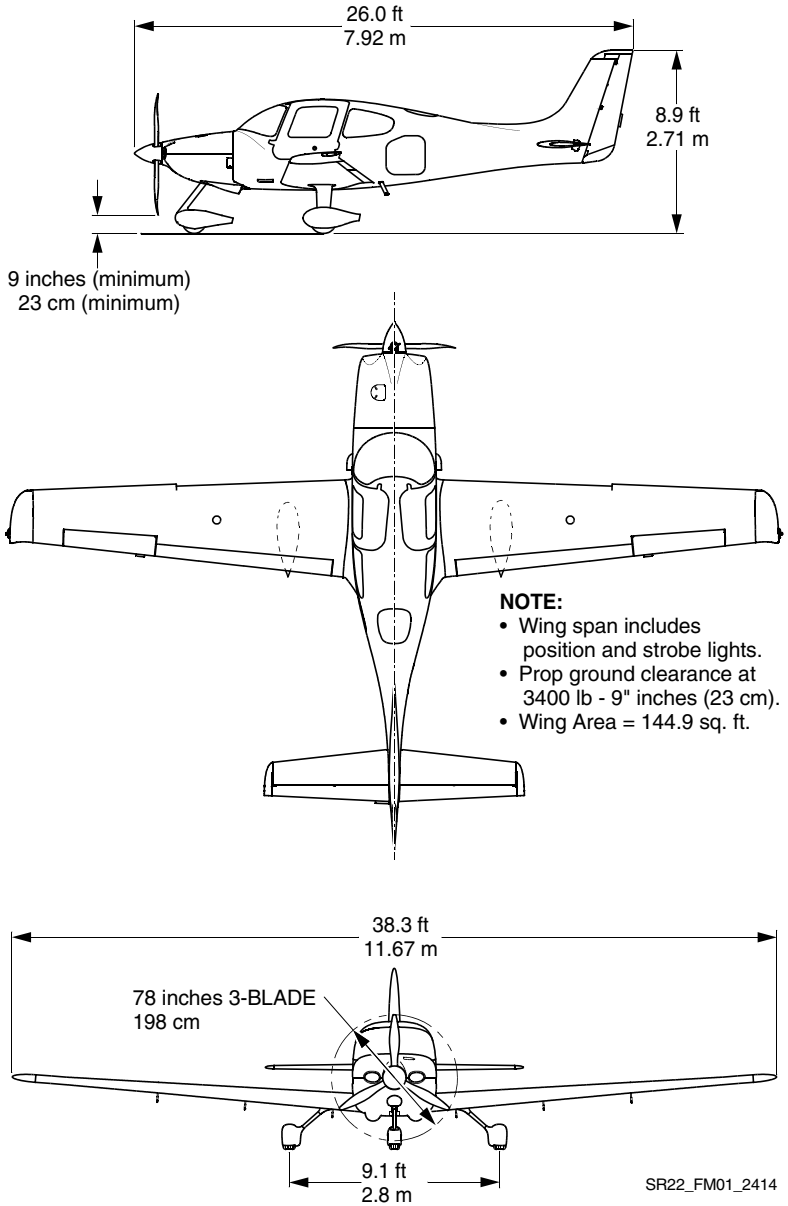

Figure - 2
Airplane Three View

The Airplane

Fuel

Total Capacity	94.5 U.S. Gallons (358.0 L)
Total Usable	92.0 U.S. Gallons (348.0 L)

Section 2 - Limitations

Airspeed Limitations

The indicated airspeeds in the following table are based upon Section 5 Airspeed Calibrations using the normal static source. When using the alternate static source, allow for the airspeed calibration variations between the normal and alternate static sources.

Speed	KIAS	KCAS	Remarks
V _{NE}	200	204	Never Exceed Speed is the speed limit that may not be exceeded at any time.
V _{NO}	177	180	Maximum Structural Cruising Speed is the speed that should not be exceeded except in smooth air, and then only with caution.
V _O 3400 Lb	133	135	Operating Maneuvering Speed is the maximum speed at which full control travel may be used. Below this speed the airplane stalls before limit loads are reached. Above this speed, full control movements can damage the airplane.
V _{FE} 50% Flaps 100% Flaps	119 104	120 104	Maximum Flap Extended Speed is the highest speed permissible with wing flaps extended.
V _{PD}	133	135	Maximum Demonstrated Parachute Deployment Speed is the maximum speed at which parachute deployment has been demonstrated.

Airspeed Indicator Markings

The airspeed indicator markings are based upon Section 5 Airspeed Calibrations using the normal static source. When using the alternate static source, allow for the airspeed calibration variations between the normal and alternate static sources.

Marking	Value (KIAS)	Remarks
White Arc	62 - 104	Full Flap Operating Range. Lower limit is the most adverse stall speed in the landing configuration. Upper limit is the maximum speed permissible with flaps extended.
Green Arc	73 - 177	Normal Operating Range. Lower limit is the maximum weight stall at most forward C.G. with flaps retracted. Upper limit is the maximum structural cruising speed.
Yellow Arc	177 - 200	Caution Range. Operations must be conducted with caution and only in smooth air.
Red Line	200	Never exceed speed. Maximum speed for all operations.

Power Plant Limitations

Propeller

MT Propeller

Propeller Type..... Constant Speed, Three Blade
 Model Number MTV-9-D/198-52
 Diameter 78.0"

Weight Limits

Maximum Takeoff Weight 3400 lb (1542 Kg)*

*no change

Center of Gravity Limits

Reference Datum 100 inches forward of firewall
 Forward Refer to Figure 3
 Aft Refer to Figure 3

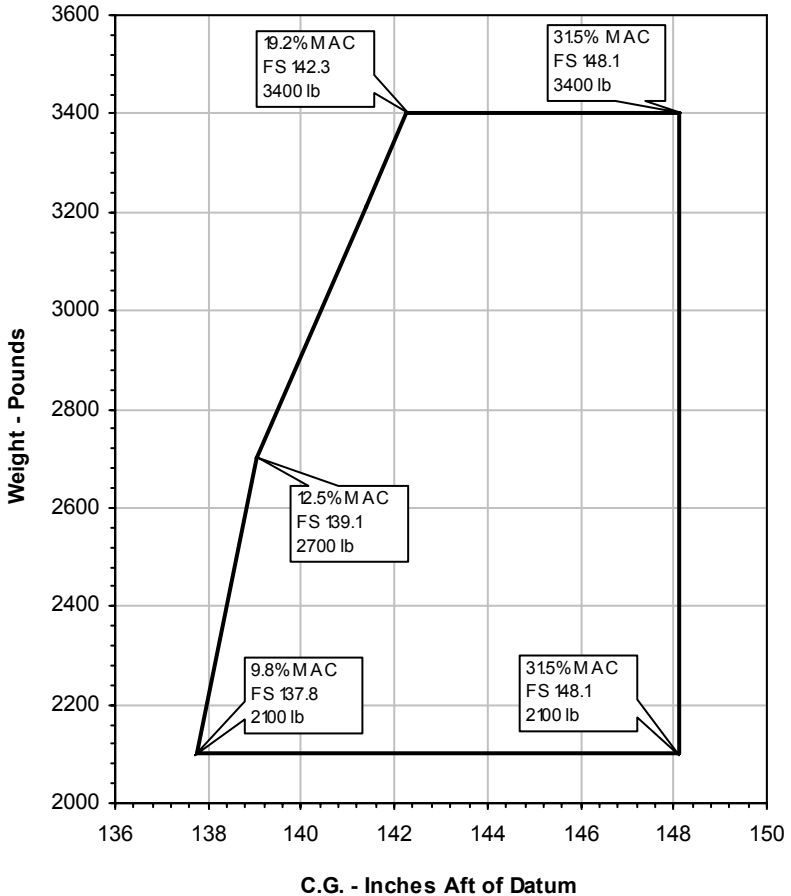

FORWARD LIMIT - The forward limit is FS 137.8 (9.8% MAC) at 2100 lb, with straight line taper to FS 139.1 (12.5% MAC) at 2700 lb, to FS 142.3 (19.2% MAC) at 3400 lb.
AFT LIMIT - The aft limit is FS 148.1 (31.5% MAC) at all weights from 2100 lb to 3400 lb.

Figure - 3
C.G. Envelope

Fuel Limits

Approved Fuel Aviation Grade 100 LL (Blue) or 100 (Green)
Total Fuel Capacity 94.5 U.S. Gallon (358.0 L)
Total Fuel Each Tank 47.25 U.S. Gallon (179.0 L)
Total Usable Fuel (all flight conditions) 92.0 U.S. Gallon (348.0 L)
Maximum Allowable Fuel Imbalance 10.0 U.S. Gallon (¼ tank)
The fuel system BOOST pump must be on for takeoff, climb, landing,
and for switching fuel tanks.

Placards

Wing, adjacent to fuel filler caps:



SR22_FM09_2584

**Figure - 4
Placards**

Intentionally Left Blank

Section 3 - Emergency Procedures

Emergency Descent

1. Power Lever IDLE
2. Mixture AS REQUIRED

• Caution •

If significant turbulence is expected do not descend at indicated airspeeds greater than V_{NO} (177 KIAS)

3. Airspeed..... V_{NE} (200 KIAS)

Smoke and Fume Elimination

If smoke and/or fumes are detected in the cabin, check the engine parameters for any sign of malfunction. If a fuel leak has occurred, actuation of electrical components may cause a fire. If there is a strong smell of fuel in the cockpit, divert to the nearest suitable landing field. Perform a *Forced Landing* pattern and shut down the fuel supply to the engine once a safe landing is assured.

1. Temperature Selector..... COLD
2. Vent Selector..... FEET/PANEL/DEFROST POSITION
3. Airflow Selector..... SET FAN SPEED TO FULL ON (3) POSITION

If source of smoke and fume is firewall forward:

- a. Airflow Selector OFF
4. Panel Eyeball Outlets..... OPEN
5. Prepare to land as soon as possible.

If airflow is not sufficient to clear smoke or fumes from cabin:

6. Cabin DoorsPARTIALLY OPEN

Airspeed may need to be reduced to partially open door in flight.

Engine Fire In Flight

If an engine fire occurs during flight, do not attempt to restart the engine.

1. Mixture CUTOFF
2. Fuel Pump.....OFF
3. Fuel Selector.....OFF
4. Airflow SelectorOFF
5. Power Lever IDLE
6. Ignition Switch.....OFF
7. Cabin Doors PARTIALLY OPEN

Airspeed may need to be reduced to partially open door in flight.

8. Land as soon as possible.

Cabin Fire In Flight

If the cause of the fire is readily apparent and accessible, use the fire extinguisher to extinguish flames and land as soon as possible. Opening the vents or doors may feed the fire, but to avoid incapacitating the crew from smoke inhalation, it may be necessary to rid cabin of smoke or fire extinguishant. If the cause of fire is not readily apparent, is electrical, or is not readily accessible, proceed as follows:

• WARNING •

If the airplane is in IMC conditions, turn ALT 1, ALT 2, and BAT 1 switches OFF. Power from battery 2 will keep the Primary Flight Display operational for approximately 30 minutes.

1. Bat-Alt Master Switches OFF, AS REQ'D

• Note •

With Bat-Alt Master Switches OFF, engine will continue to run. However, no electrical power will be available.

2. Fire Extinguisher ACTIVATE

• **WARNING** •

Halon gas used in the fire extinguisher can be toxic, especially in a closed area. After extinguishing fire, ventilate cabin by and unlatching door (if required).

If airflow is not sufficient to clear smoke or fumes from cabin:

3. Cabin Doors**PARTIALLY OPEN**
Airspeed may need to be reduced to partially open door in flight.
4. Avionics Power Switch **OFF**
5. All other switches **OFF**
6. Land as soon as possible.

If setting master switches off eliminated source of fire or fumes and airplane is in night, weather, or IFR conditions:

• **WARNING** •

If airplane is in day VFR conditions and turning off the master switches eliminated the fire situation, leave the master switches OFF. Do not attempt to isolate the source of the fire by checking each individual electrical component.

7. Airflow Selector **OFF**
8. Bat-Alt Master Switches **ON**
9. Avionics Power Switch **ON**
10. Activate required systems one at a time. Pause several seconds between activating each system to isolate malfunctioning system. Continue flight to earliest possible landing with malfunctioning system off. Activate only the minimum amount of equipment necessary to complete a safe landing.
11. Temperature Selector **COLD**
12. Vent Selector **FEET/PANEL/DEFROST POSITION**
13. Airflow Selector **SET FAN SPEED TO FULL ON (3) POSITION**
14. Panel Eyeball Outlets **OPEN**

Intentionally Left Blank

Section 4 - Normal Procedures

Airspeeds for Normal Operation

Unless otherwise noted, the following speeds are based on a maximum weight of 3400 lb. and may be used for any lesser weight. However, to achieve the performance specified in Section 5 for takeoff and landing distance, the speed appropriate to the particular weight must be used.

Takeoff Rotation:

- Normal, Flaps 50%..... 70 KIAS
- Obstacle Clearance, Flaps 50%..... 78 KIAS

Enroute Climb, Flaps Up:

- Normal..... 110-120 KIAS
- Best Rate of Climb, SL 101 KIAS
- Best Rate of Climb, 10,000..... 96 KIAS
- Best Angle of Climb, SL..... 79 KIAS
- Best Angle of Climb, 10,000 83 KIAS

Landing Approach:

- Normal Approach, Flaps Up.....90-95 KIAS
- Normal Approach, Flaps 50%85-90 KIAS
- Normal Approach, Flaps 100%80-85 KIAS
- Short Field, Flaps 100% (V_{REF}) 77 KIAS

Go-Around, Flaps 50%:

- Full Power..... 80 KIAS

Maximum Recommended Turbulent Air Penetration:

- 3400 lb..... 133 KIAS
- 2900 lb..... 123 KIAS

Maximum Demonstrated Crosswind Velocity:

- Takeoff or Landing20 Knots

Short Field Takeoff

1. Flaps50%
2. Brakes HOLD
3. Power Lever FULL FORWARD
4. Mixture SET
5. Engine Parameters CHECK
6. Brakes RELEASE (Steer with Rudder Only)
7. Elevator Control ROTATE Smoothly at 70 KIAS
8. Airspeed at Obstacle.....78 KIAS

Section 5 - Performance

Airspeed Calibration

Normal Static Source

Conditions:

- Power for level flight or maximum continuous, whichever is less.

Example:

Flaps.....50%
Indicated Airspeed.....90 Knots

Calibrated Airspeed.....91 Knots

• Note •

- Indicated airspeed values assume zero instrument error.

KIAS	KCAS		
	Flaps 0%	Flaps 50%	Flaps 100%
60	57	56	57
70	68	68	70
80	79	80	80
90	89	91	89
100	100	101	99
110	111	111	
120	121	121	
130	132		
140	142		
150	152		
160	163		
170	173		
180	183		
190	193		
200	204		
210	213		
220	223		
200	203		

Airspeed Calibration

Alternate Static Source

Conditions:

- Power for level flight or maximum continuous, whichever is less.
- Heater, Defroster & Vents..... ON

Example:

Flaps 50%
 Indicated Airspeed 90 Knots

 Calibrated Airspeed 83 Knots

• Note •

- Indicated airspeed values assume zero instrument error.

KIAS	KCAS		
	Flaps 0%	Flaps 50%	Flaps 100%
60	61	58	54
70	68	66	63
80	77	74	72
90	85	83	82
100	94	92	92
110	103	102	101
120	112	112	
130	121	122	
140	131		
150	141		
160	150		
170	160		
180	170		
190	179		
200	189		
210	198		

Altitude Correction

Normal Static Source

Conditions:

- Power for level flight or maximum continuous, whichever is less.
- 3400 LB

• Note •

- Add correction to desired altitude to obtain indicated altitude to fly.
- Indicated airspeed values assume zero instrument error.
- KIAS = Knots Indicated Airspeed.

Flaps	Press Alt	CORRECTION TO BE ADDED - FEET									
		Normal Static Source - KIAS									
		60	70	80	90	100	120	140	160	180	200
0%	S.L		12	9	5	0	-11	-23	-36	-49	-59
	5000		13	10	5	0	-13	-27	-42	-56	-69
	10000		16	12	6	0	-15	-32	-49	-66	-80
	15000		18	14	7	0	-17	-37	-58	-77	-94
50%	S.L		9	2	-4	-10	-16				
	5000		11	3	-5	-12	-18				
	10000		12	3	-6	-14	-22				
100%	S.L	10	1	-1	2	6					
	5000	10	-1	1	6	6					
	10000	37	45	48	50	56					

Altitude Correction

Alternate Static Source

Conditions:

- Power for level flight or maximum continuous, whichever is less.
- Heater, Defroster, & Vents ON

• Note •

- Add correction to desired altitude to obtain indicated altitude to fly.
- Indicated airspeed values assume zero instrument error.
- KIAS = Knots Indicated Airspeed.

Flaps	Press Alt	CORRECTION TO BE ADDED - FEET									
		Normal Static Source - KIAS									
		60	70	80	90	100	120	140	160	180	200
0%	S.L		12	28	43	57	82	104	126	148	172
	5000		16	35	54	71	104	136	168	203	242
	10000		20	43	66	87	128	169	211	258	311
	15000		23	51	78	103	152	200	251	308	373
50%	S.L		43	65	87	108	148				
	5000		21	32	39	42	26				
	10000		36	54	70	82	88				
100%	S.L	42	56	67	80	95					
	5000	37	45	48	50	56					
	10000	61	81	99	119	148					

Stall Speeds

Conditions:

- Weight3400 LB
- C.G.....Noted
- Power Idle
- Bank Angle.....Noted

Example:

- Flaps.....Up (0%)
 - Bank Angle 15°
 - C.G Forward
-
- Stall Speed74 KIAS | 71 KCAS

• Note •

- Altitude loss during wings level stall may be 600 feet or more.
- KIAS values may not be accurate at stall.

Weight	Bank Angle	STALL SPEEDS					
		Flaps 0% Full Up		Flaps 50%		Flaps 100% Full Down	
LB	Deg	KIAS	KCAS	KIAS	KCAS	KIAS	KCAS
3400 Most FWD C.G.	0	73	70	66	64	62	60
	15	74	71	67	65	64	61
	30	76	75	71	69	66	64
	45	83	83	77	76	72	71
	60	99	99	90	90	84	84
3400 Most AFT C.G.	0	72	69	65	63	60	58
	15	73	70	66	64	61	59
	30	76	74	69	67	63	62
	45	82	82	76	75	69	69
	60	98	98	89	89	82	82

Takeoff Distance

Conditions:

- Winds..... Zero
- Runway..... Dry, Level, Paved
- Flaps..... 50%
- Power..... Full Throttle
- Mixture..... Set per Placard

Example:

Outside Air Temp	20°C
Weight.....	3400 LB
Pressure Altitude.....	2000 FT
Headwind	Zero
Runway	Dry, Paved
Liftoff Speed.....	72 KIAS
Obstacle Speed	78 KIAS
Takeoff Ground Roll	1299 FT
Dist. over 50' Obstacle	1995 FT

Factors:

The following factors are to be applied to the computed takeoff distance for the noted condition:

- Headwind - Subtract 10% from computed distance for each 12 knots headwind.
- Tailwind - Add 10% for each 2 knots tailwind up to 10 knots.
- Grass Runway, Dry - Add 20% to ground roll distance.
- Grass Runway, Wet - Add 30% to ground roll distance.
- Sloped Runway - Increase table distances by 22% of the ground roll distance at Sea Level, 30% of the ground roll distance at 5000 ft, 43% of the ground roll distance at 10,000 ft for each 1% of upslope. Decrease table distances by 7% of the ground roll distance at Sea Level, 10% of the ground roll distance at 5000 ft, and 14% of the ground roll distance at 10,000 ft for each 1% of downslope.

• Caution •

The above corrections for runway slope are required to be included herein. These corrections should be used with caution since published runway slope data is usually the net slope from one end of the runway to the other. Many runways will have portions of their length at greater or lesser slopes than the published slope, lengthening (or shortening) takeoff ground roll estimated from the table.

- If brakes are not held while applying power, distances apply from point where full throttle and mixture setting is complete.
- For operation in outside air temperatures colder than this table provides, use coldest data shown.
- For operation in outside air temperatures warmer than this table provides, use extreme caution.

Takeoff Distance

PRESS ALT FT		DISTANCE FT		TEMPERATURE ~ °C				ISA
		0	10	20	30	40		
WEIGHT = 3400 LB Speed at Liftoff = 73 KIAS Speed over 50 Ft. Obstacle = 78 KIAS Flaps - 50% · Takeoff Pwr · Dry Paved		Headwind: Subtract 10% for each 12 knots headwind.						
		Tailwind: Add 10% for each 2 knots tailwind up to 10 knots.						
		Runway Slope: Ref. Factors.						
		Dry Grass: Add 20% to Ground Roll.						
		Wet Grass: Add 30% to Ground Roll.						
SL	Grnd Roll	917	990	1067	1146	1229	1028	
	50 ft	1432	1539	1650	1764	1883	1594	
1000	Grnd Roll	1011	1092	1176	1264	1355	1117	
	50 ft	1574	1691	1813	1939	2069	1728	
2000	Grnd Roll	1116	1206	1299	1395	1496	1215	
	50 ft	1732	1861	1995	2133	2276	1874	
3000	Grnd Roll	1234	1332	1435	1542	1653	1323	
	50 ft	1907	2049	2196	2349	2507	2035	
4000	Grnd Roll	1365	1474	1588	1706	1829	1441	
	50 ft	2102	2259	2422	2590	2764	2212	
5000	Grnd Roll	1512	1633	1758	1889	2025	1572	
	50 ft	2320	2493	2673	2858	3051	2407	
6000	Grnd Roll	1676	1810	1950	2095	2245	1717	
	50 ft	2564	2755	2953	3159	3371	2622	
7000	Grnd Roll	1861	2009	2164	2325	2492	1877	
	50 ft	2837	3048	3267	3494	3729	2859	
8000	Grnd Roll	2068	2233	2405	2584	2770	2054	
	50 ft	3142	3376	3619	3871	4131	3122	
9000	Grnd Roll	2302	2485	2677	2875	3082	2250	
	50 ft	3485	3744	4014	4293	4581	3412	
10000	Grnd Roll	2564	2769	2982	3204	3434	2468	
	50 ft	3870	4158	4457	4767	5088	3733	

Takeoff Distance

PRESS ALT FT		DISTANCE FT	TEMPERATURE ~ °C					ISA
			0	10	20	30	40	
SL	Grnd Roll	610	659	710	763	818	684	
	50 ft	971	1043	1118	1195	1275	1080	
1000	Grnd Roll	673	727	783	841	902	743	
	50 ft	1066	1146	1228	1313	1401	1170	
2000	Grnd Roll	743	802	864	929	995	809	
	50 ft	1173	1260	1351	1444	1541	1269	
3000	Grnd Roll	821	887	955	1026	1100	880	
	50 ft	1292	1388	1487	1590	1697	1378	
4000	Grnd Roll	908	981	1057	1135	1217	959	
	50 ft	1424	1530	1639	1753	1871	1498	
5000	Grnd Roll	1006	1086	1170	1257	1348	1046	
	50 ft	1571	1688	1809	1935	2065	1630	
6000	Grnd Roll	1116	1205	1298	1394	1494	1143	
	50 ft	1736	1865	1999	2138	2281	1775	
7000	Grnd Roll	1238	1337	1440	1547	1659	1249	
	50 ft	1920	2063	2211	2365	2523	1936	
8000	Grnd Roll	1376	1486	1601	1720	1843	1367	
	50 ft	2127	2285	2449	2619	2795	2113	
9000	Grnd Roll	1532	1654	1781	1914	2051	1498	
	50 ft	2359	2534	2716	2904	3099	2309	
10000	Grnd Roll	1707	1843	1985	2132	2285	1643	
	50 ft	2619	2814	3016	3225	3441	2527	

WEIGHT = 2900 LB
Speed at Liftoff = 70 KIAS
Speed over 50 Ft Obstacle = 74 KIAS
 Flaps - 50% · Takeoff Pwr · Dry Paved

Headwind: Subtract 10% for each 12 knots headwind.
Tailwind: Add 10% for each 2 knots tailwind up to 10 knots.
Runway Slope: Ref. Factors.
Dry Grass: Add 20% to Ground Roll.
Wet Grass: Add 30% to Ground Roll.

Takeoff Climb Gradient

Conditions:

- Power Full Throttle
- Mixture Set per Placard
- Flaps 50%
- Airspeed Best Rate of Climb

Example:

Outside Air Temp 20° C
 Weight 3400 LB
 Pressure Altitude 4000 FT

Climb Airspeed 89 Knots
 Gradient 654 FT/NM

• Note •

- Climb Gradients shown are the gain in altitude for the horizontal distance traversed expressed as Feet per Nautical Mile.
- Fuel flow must be set to the placarded limit for all takeoffs and climbs.
- Cruise climbs or short duration climbs are permissible at best power as long as altitudes and temperatures remain within those specified in the table.
- For operation in air colder than this table provides, use coldest data shown.
- For operation in air warmer than this table provides, use extreme caution.

Weight LB	Press Alt FT	Climb Speed KIAS	CLIMB GRADIENT ~ Feet per Nautical Mile				
			Temperature ~ °C				
			-20	0	20	40	ISA
3400	SL	91	939	896	853	811	864
	2000	90	834	793	75.2	711	770
	4000	89	734	694	654	615	680
	6000	88	638	600	561	524	594
	8000	88	546	509	472	436	510
	10000	87	458	422	387	353	431
2900	SL	91	1172	1122	1070	1019	1083
	2000	90	1049	1000	950	902	972
	4000	89	931	884	836	790	867
	6000	88	818	773	727	683	766
	8000	88	711	667	623	581	669
	10000	87	608	566	524	484	576

Takeoff Rate of Climb

Conditions:

- Power.....Full Throttle
- Mixture.....Set per Placard
- Flaps..... 50%
- AirspeedBest Rate of Climb

Example:

Outside Air Temp 10° C
 Weight..... 3400 LB
 Pressure Altitude..... 6000 FT

Climb Airspeed..... 88 Knots
 Rate of Climb 948 FPM

• Note •

- Rate-of-Climb values shown are change in altitude for unit time expended expressed in Feet per Minute.
- Fuel flow must be set to the placarded limit for all takeoffs and climbs.
- Cruise climbs or short duration climbs are permissible at best power as long as altitudes and temperatures remain within those specified in the table.
- For operation in air colder than this table provides, use coldest data shown.
- For operation in air warmer than this table provides, use extreme caution.

Weight LB	Press Alt FT	Climb Speed KIAS	RATE OF CLIMB ~ Feet per Minute				
			Temperature ~ °C				
			-20	0	20	40	ISA
3400	SL	91	1326	1317	1300	1277	1304
	2000	90	1214	1200	1179	1153	1189
	4000	89	1100	1082	1057	1028	1074
	6000	88	985	962	934	901	958
	8000	88	869	842	809	774	843
	10000	87	851	719	683	644	727
2900	SL	91	1646	1638	1621	1598	1626
	2000	90	1518	1505	1484	1457	1494
	4000	89	1389	1371	1346	1316	1363
	6000	88	1259	1236	1207	1172	1232
	8000	88	1128	1100	1066	1028	1101
	10000	87	995	962	924	883	971

Enroute Climb Gradient

Conditions:

- Power Full Throttle
- Mixture Full Rich
- Flaps 0% (UP)
- Airspeed Best Rate of Climb

Example:

Outside Air Temp 20° C
 Weight 3400 LB
 Pressure Altitude 4000 FT

Climb Airspeed 98 Knots
 Gradient 639 FT/NM

• Note •

- Climb Gradients shown are the gain in altitude for the horizontal distance traversed expressed as Feet per Nautical Mile.
- Fuel flow must be set to the placarded limit for all takeoffs and climbs.
- Cruise climbs or short duration climbs are permissible at best power as long as altitudes and temperatures remain within those specified in the table.
- For operation in air colder than this table provides, use coldest data shown.
- For operation in air warmer than this table provides, use extreme caution.

Weight LB	Press Alt FT	Climb Speed KIAS	CLIMB GRADIENT - Feet per Nautical Mile				
			Temperature ~ °C				
			-20	0	20	40	ISA
3400	SL	101	911	867	823	781	834
	2000	100	813	771	729	689	748
	4000	99	720	679	639	600	665
	6000	98	630	590	552	515	584
	8000	97	544	505	468	433	507
	10000	96	461	424	388	354	433
	12000	95	381	346	312	279	361
	14000	94	304	271	238	207	292
16000	93	231	199	168	139	226	
2900	SL	101	1130	1078	1026	975	1039
	2000	100	1015	965	915	867	937
	4000	99	905	857	809	763	840
	6000	98	800	753	708	664	746
	8000	97	699	654	611	569	656
	10000	96	603	560	518	478	570
	12000	95	610	469	429	391	487
	14000	94	422	382	344	308	407
16000	93	337	299	263	229	331	

Enroute Rate of Climb

Conditions:

- Power.....Full Throttle
- Mixture.....As Required
- Flaps.....0% (UP)
- AirspeedBest Rate of Climb

Example:

Outside Air Temp 10° C
 Weight.....3400 LB
 Pressure Altitude.....6000 FT

Climb Airspeed..... 97 Knots
 Rate of Climb 1030 FPM

• Note •

- Rate-of-Climb values shown are change in altitude in feet per unit time expressed in Feet per Minute.
- Fuel flow must be set to the placarded limit for all takeoffs and climbs.
- Cruise climbs or short duration climbs are permissible at best power as long as altitudes and temperatures remain within those specified in the table.
- For operation in air colder than this table provides, use coldest data shown.
- For operation in air warmer than this table provides, use extreme caution.

Weight LB	Press Alt FT	Climb Speed KIAS	RATE OF CLIMB ~ Feet per Minute				
			Temperature ~ °C				
			-20	0	20	40	ISA
3400	SL	101	1428	1414	1392	1366	1398
	2000	100	1311	1292	1267	1238	1279
	4000	99	1193	1170	1141	1108	1160
	6000	98	1074	1046	1013	977	1041
	8000	97	953	921	884	845	922
	10000	96	830	794	754	712	803
	12000	95	706	666	623	577	684
	14000	94	581	537	490	441	565
2900	SL	101	1761	1748	1726	1698	1732
	2000	100	1629	1610	1584	1552	1596
	4000	99	1494	1471	1441	1405	1461
	6000	98	1359	1331	1296	1257	1326
	8000	97	1222	1189	1151	1108	1191
	10000	95	1084	1046	1004	958	1056
	12000	95	945	902	855	806	921
	14000	93	804	757	706	653	787
	16000	92	662	610	556	499	653

Time, Fuel and Distance to Climb

Conditions:

- Power Full Throttle
- Mixture Per Schedule, Section 4
- Fuel Density 6.0 LB/GAL
- Weight 3400 LB
- Winds Zero
- Climb Airspeed Noted

Example:

- Outside Air Temp ISA
- Weight 3400 LB
- Airport Pressure Altitude 1000 FT
- Pressure Altitude 12000 FT

- Time to Climb 11.3 Minutes
- Fuel to Climb 5.6 Gallon
- Distance to Climb 20.5 NM

Factors:

- Taxi Fuel - Add 1.5 gallon for start, taxi, and takeoff.
- Temperature - Add 10% to computed values for each 10° C above standard.
- Fuel flow must be set to the placarded limit for all takeoffs and climbs.
- Cruise climbs or short duration climbs are permissible at best power as long as altitudes and temperatures remain within those specified in the table.

Press Alt FT	OAT (ISA) °C	Climb Speed KIAS	Rate Of Climb FPM	TIME, FUEL, DISTANCE ~ From Sea Level		
				Time Minutes	Fuel U.S. Gal	Distance NM
SL	15	101	1398	0.0	0.0	0.0
1000	13	100	1339	0.7	0.3	1.0
2000	11	100	1279	1.5	0.7	2.5
3000	9	99	1220	2.5	1.0	4.0
4000	7	99	1160	3.0	1.3	5.5
5000	5	97	1101	4.0	1.7	7.0
6000	3	98	1041	5.0	2.0	8.5
7000	1	96	982	6.0	2.4	10.5
8000	-1	97	922	7.0	2.7	12.0
9000	-3	95	863	8.0	3.1	14.5
10000	-5	95	803	9.5	3.5	16.5
11000	-7	94	744	10.5	3.9	19.0
12000	-9	95	684	12.0	4.4	21.5
13000	-11	93	625	13.5	4.8	24.5
14000	-13	93	565	15.0	5.3	28.0
15000	-15	92	506	17.0	5.8	31.5
16000	-17	92	446	19.0	6.4	35.5
17000	-19	91	387	21.5	7.1	40.0
17500	-20	91	357	24.0	7.8	45.5

Range / Endurance Profile

Conditions:

- Weight 3400 LB
- Temperature Standard Day
- Winds..... Zero
- Mixture..... Best Economy
- Total Fuel 92 Gallons

Example:

- Power Setting 55%
- Takeoff Press Alt 2000 FT
- Cruise Press Alt 6000 FT

- Fuel to Climb..... 1.3 Gal.
- Cruise Fuel Flow 11.3 GPH
- Endurance..... 6.1 Hr
- Range 962 NM
- True Airspeed..... 157 Knots

• Note •

- Fuel Remaining For Cruise is equal to 92.0 gallons usable, less climb fuel, less 9.8 gallons for 45 minutes IFR reserve fuel at 47% power (ISA @ 10,000 ft PA), less descent fuel, less fuel used prior to takeoff.
- Range and endurance shown includes descent to final destination at approximately 178 KIAS and 500 fpm
- Range is decreased by 5% if nose wheel pant and fairings removed.
- Range is decreased by 15% if nose and main wheel pants and fairings removed.

75% POWER Mixture = Best Power							
Press Alt	Climb Fuel	Fuel Remaining For Cruise	Airspeed	Fuel Flow	Endurance	Range	Specific Range
FT	Gal	Gal	KTAS	GPH	Hours	NM	Nm/Gal
SL	0.0	81.3	166	17.8	4.6	763	9.3
2000	0.7	81.1	170	17.8	4.6	775	9.6
4000	1.3	80.4	173	17.8	4.5	786	9.8
6000	2.0	79.7	177	17.8	4.5	797	10.0
8000	2.7	79.0	180	17.8	4.4	811	10.3

Range / Endurance Profile

65% POWER Mixture = Best Power							
Press Alt	Climb Fuel	Fuel Remaining For Cruise	Airspeed	Fuel Flow	Endurance	Range	Specific Range
FT	Gal	Gal	KTAS	GPH	Hours	NM	Nm/Gal
SL	0.0	81.3	158	15.4	5.3	838	10.3
2000	0.7	81.1	161	15.4	5.3	850	10.5
4000	1.3	80.4	165	15.4	5.2	862	10.7
6000	2.0	79.7	168	15.4	5.2	874	11.0
8000	2.7	79.0	171	15.4	5.1	887	11.2
10000	3.5	78.2	174	15.4	5.1	899	11.5
12000	4.4	77.1	178	15.4	5.0	912	11.8

55% POWER Mixture = Best Power							
Press Alt	Climb Fuel	Fuel Remaining For Cruise	Airspeed	Fuel Flow	Endurance	Range	Specific Range
FT	Gal	Gal	KTAS	GPH	Hours	NM	Nm/Gal
SL	0.0	81.8	149	13.1	6.3	931	11.4
2000	0.7	81.1	152	13.1	6.2	943	11.6
4000	1.3	80.4	154	13.1	6.2	955	11.9
6000	2.0	79.7	157	13.1	6.1	968	12.2
8000	2.7	79.0	160	13.1	6.0	980	12.4
10000	3.5	78.3	163	13.1	6.0	993	12.7
12000	4.4	77.4	166	13.1	5.9	1005	13.0
14000	5.3	76.5	169	13.1	5.8	1018	13.4

Range / Endurance Profile

55% POWER Mixture = Best Economy							
Press Alt	Climb Fuel	Fuel Remaining For Cruise	Airspeed	Fuel Flow	Endurance	Range	Specific Range
FT	Gal	Gal	KTAS	GPH	Hours	NM	Nm/Gal
SL	0.0	81.8	149	11.3	7.2	1074	13.1
2000	0.7	81.1	152	11.3	7.2	1088	13.4
4000	1.3	80.4	154	11.3	7.1	1108	13.7
6000	2.0	79.7	157	11.3	7.0	1115	14.0
8000	2.7	79.0	160	11.3	7.0	1129	14.3
10000	3.5	78.3	163	11.3	6.9	1143	14.6
12000	4.4	77.4	166	11.3	6.8	1156	15.0
14000	5.3	76.5	169	11.3	6.7	1170	15.4

Balked Landing Climb Gradient

Conditions:

- Power Full Throttle
- Mixture Set per Placard
- Flaps 100% (DN)
- Climb Airspeed..... V_{REF}

Example:

Outside Air Temp.....20° C
 Weight 3400 LB
 Pressure Altitude 4000 FT

Climb Airspeed77 Knots
 Rate of Climb.....633 FT/NM

• Note •

- Balked Landing Climb Gradients shown are the gain in altitude for the horizontal distance traversed expressed as Feet per Nautical Mile.
- For operation in air colder than this table provides, use coldest data shown.
- For operation in air warmer than this table provides, use extreme caution.
- This chart is required data for certification. However, significantly better performance can be achieved by climbing at Best Rate of Climb speeds shown with flaps down or following the Go-Around / Balked Landing procedure in Section 4.

Weight LB	Press Alt FT	Climb Speed KIAS	CLIMB GRADIENT ~ Feet/Nautical Mile					Best Rate of Climb KIAS
			Temperature ~ °C					
			-20	0	20	40	ISA	
3400	SL	77	834	835	823	803	827	80
	2000	77	750	744	728	704	736	80
	4000	77	666	654	633	604	648	79
	6000	77	581	564	537	504	560	78
	8000	77	496	472	440	402	473	77
	10000	77	409	379	341	296	387	77
2900	SL	77	1069	1070	1056	1032	1060	
	2000	77	969	962	942	914	953	
	4000	77	869	855	829	796	847	
	6000	77	789	747	716	677	743	
	8000	77	668	639	602	556	641	
	10000	77	565	529	484	432	639	

Balked Landing Rate of Climb

Conditions:

- Power.....Full Throttle
- Mixture.....Set per Placard
- Flaps..... 100% (DN)
- Climb Airspeed V_{REF}

Example:

Outside Air Temp 20° C
 Weight..... 3400 LB
 Pressure Altitude..... 4000 FT

Climb Airspeed..... 77 Knots
 Rate of Climb 878 FT/NM

• Note •

- Balked Landing Rate of Climb values shown are the full flaps change in altitude for unit time expended expressed in Feet per Minute.
- For operation in air colder than this table provides, use coldest data shown.
- For operation in air warmer than this table provides, use extreme caution.
- This chart is required data for certification. However, significantly better performance can be achieved by climbing at the Best Rate of Climb speeds shown with flaps down or following the Go-Around / Balked Landing procedure in Section 4

Weight LB	Press Alt FT	Climb Speed KIAS	RATE OF CLIMB - Feet per Minute					Best Rate of Climb KIAS
			Temperature ~ °C					
			-20	0	20	40	ISA	
3400	SL	77	996	1035	1057	1067	1053	80
	2000	77	930	959	972	971	966	80
	4000	77	858	876	878	867	878	79
	6000	77	779	784	775	752	784	78
	8000	77	691	683	660	623	684	77
	10000	77	593	571	532	478	578	77
2900	SL	77	1268	1318	1348	1363	1342	
	2000	77	1195	1233	1252	1255	1245	
	4000	77	1115	1140	1146	1137	1144	
	6000	77	1026	1037	1030	1007	1037	
	8000	77	927	923	900	861	923	
	10000	77	817	796	755	696	803	

Landing Distance

Conditions:

- WindsZero
- Runway Dry, Level, Paved
- Flaps. 100%
- Power 3° Power Approach to 50 FT obstacle, then reduce power passing the estimated 50 foot point and smoothly continue power reduction to reach idle just prior to touchdown.

Example:

- Outside Air Temp 10°C
 - Weight 3400 LB
 - Pressure Altitude 2000 FT
 - Headwind Zero
-
- Obstacle Speed (V_{REF}) 77 KIAS
 - Landing Ground Roll 1206 FT
 - Dist. over 50' Obstacle..... 2436 FT

Factors:

The following factors are to be applied to the computed landing distance for the noted condition:

- Headwind - Subtract 10% from table distances for each 13 knots headwind.
- Tailwind - Add 10% to table distances for each 2 knots tailwind up to 10 knots.
- Grass Runway, Dry - Add 20% to ground roll distance.
- Grass Runway, Wet - Add 60% to ground roll distance.
- Sloped Runway - Increase table distances by 27% of the ground roll distance for each 1% of downslope. Decrease table distances by 9% of the ground roll distance for each 1% of upslope.

• Caution •

The above corrections for runway slope are required to be included herein. These corrections should be used with caution since published runway slope data is usually the net slope from one end of the runway to the other. Many runways will have portions of their length at greater or lesser slopes than the published slope, lengthening (or shortening) landing ground roll estimated from the table.

- For operation in outside air temperatures colder than this table provides, use coldest data shown
- For operation in outside air temperatures warmer than this table provides, use extreme caution.

Landing Distance

WEIGHT = 3400 LB Speed over 50 Ft Obstacle = 77 KIAS Flaps - 100% - Idle - Dry, Level Paved Surface		Headwind: Subtract 10% for each 13 knots headwind. Tailwind: Add 10% for each 2 knots tailwind up to 10 knots. Runway Slope: Ref. Factors. Dry Grass: Add 20% to Ground Roll Wet Grass: Add 60% to Ground Roll					
PRESS ALT FT	DISTANCE FT	TEMPERATURE ~ °C					ISA
		0	10	20	30	40	
SL	Grnd Roll	1082	1121	1161	1200	1240	1141
	Total	2262	2316	2372	2428	2485	2344
1000	Grnd Roll	1122	1163	1204	1245	1286	1175
	Total	2317	2374	2433	2492	2551	2391
2000	Grnd Roll	1163	1206	1248	1291	1334	1210
	Total	2375	2436	2497	2559	2621	2441
3000	Grnd Roll	1207	1251	1295	1339	1384	1247
	Total	2437	2501	2565	2630	2696	2493
4000	Grnd Roll	1252	1298	1344	1390	1436	1285
	Total	2503	2569	2637	2705	2774	2548
5000	Grnd Roll	1300	1348	1395	1443	1490	1324
	Total	2572	2642	2713	2785	2857	2605
6000	Grnd Roll	1350	1399	1449	1498	1547	1365
	Total	2645	2719	2794	2869	2945	2665
7000	Grnd Roll	1402	1453	1504	1556	1607	1408
	Total	2723	2800	2879	2958	3038	2728
8000	Grnd Roll	1456	1509	1563	1616	1669	1452
	Total	2805	2887	2969	3052	3136	2794
9000	Grnd Roll	1513	1569	1624	1679	1735	1497
	Total	2892	2978	3064	3152	3240	2863
10000	Grnd Roll	1573	1630	1688	1746	1803	1545
	Total	2984	3074	3165	3257	3350	2936

Section 6 - Weight and Balance

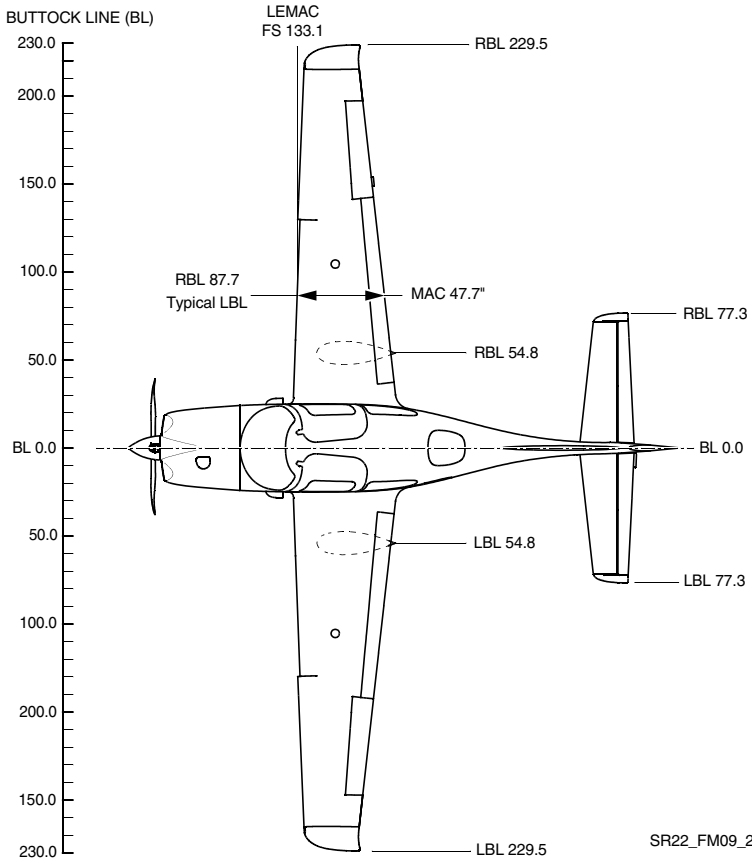
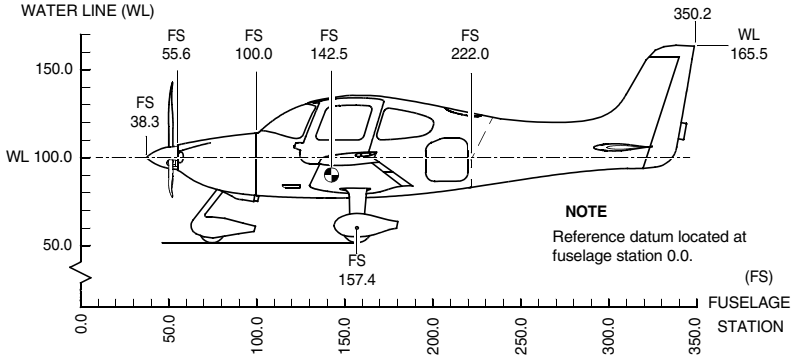

SR22_FM09_2607

Airplane Weighing Form

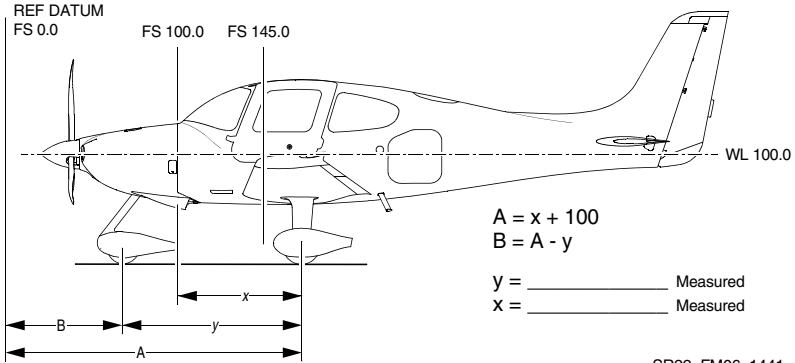

Weighing Point	Scale Reading	- Tare	= Net Weight	X Arm	= Moment
L Main				A=	
R Main				A=	
Nose				B=	
Total As Weighed				CG=	
CG = Total Moment ÷ Total Weight					
<i>Space below provided for additions or subtractions to as weighed condition</i>					
Empty Weight				CG=	
Engine Oil (if oil drained) <i>15 lb at FS 78.4, moment = 1176</i>					
Unusable Fuel			15.0	154.9	2324
Basic Empty Weight				CG=	

Figure - 5
Airplane Dimensional Data

Airplane Weighing Procedures

A basic empty weight and center of gravity were established for this airplane when the airplane was weighed just prior to initial delivery. However, major modifications, loss of records, addition or relocation of equipment, accomplishment of service bulletins, and weight gain over time may require re-weighing to keep the basic empty weight and center of gravity current. The frequency of weighing is determined by the operator. All changes to the basic empty weight and center of gravity are the responsibility of the operator. *Refer to Section 8 for specific servicing procedures.*

1. Preparation:
 - a. Inflate tires to recommended operating pressures.
 - b. Service brake reservoir.
 - c. Drain fuel system.
 - d. Drain ice protection system.
 - e. Service engine oil.
 - f. Move crew seats to the most forward position.
 - g. Raise flaps to the fully retracted position.
 - h. Place all control surfaces in neutral position.
 - i. Verify equipment installation and location by comparison to equipment list.
2. Leveling:
 - a. Level longitudinally with a spirit level placed on the pilot door sill and laterally with of a spirit level placed across the door sills. Alternately, level airplane by sighting the forward and aft tool holes along waterline 95.9.
 - b. Place scales under each wheel (minimum scale capacity, 500 pounds nose, 1000 pounds each main).
 - c. Deflate the nose tire and/or shim underneath scales as required to properly center the bubble in the level.

3. Weighing:
 - a. With the airplane level, doors closed, and brakes released, record the weight shown on each scale. Deduct the tare, if any, from each reading.
4. Measuring:
 - a. Obtain measurement 'x' by measuring horizontally along the airplane center line (BL 0) from a line stretched between the main wheel centers to a plumb bob dropped from the forward side of the firewall (FS 100). Add 100 to this measurement to obtain left and right weighing point arm (dimension 'A'). Typically, dimension 'A' will be in the neighborhood of 157.5.
 - b. Obtain measurement 'y' by measuring horizontally and parallel to the airplane centerline (BL 0), from center of nosewheel axle, left side, to a plumb bob dropped from the line stretched between the main wheel centers. Repeat on right side and average the measurements. Subtract this measurement from dimension 'A' to obtain the nosewheel weighing point arm (dimension 'B').
5. Determine and record the moment for each of the main and nose gear weighing points using the following formula:

$$\text{Moment} = \text{Net Weight} \times \text{Arm}$$

6. Calculate and record the as-weighed weight and moment by totaling the appropriate columns.
7. Determine and record the as-weighed C.G. in inches aft of datum using the following formula:

$$\text{C.G.} = \text{Total Moment} \div \text{Total Weight}$$

8. Add or subtract any items not included in the as-weighed condition to determine the empty condition. Application of the above C.G. formula will determine the C.G for this condition.
9. Add the correction for engine oil (15 lb at FS 78.4), if the airplane was weighed with oil drained. Add the correction for unusable fuel (15.0 lb at FS 154.9) to determine the Basic Empty Weight and Moment. Calculate and record the Basic Empty Weight C.G. by applying the above C.G. formula.

10. Record the new weight and C.G. values on the Weight and Balance Record.

The above procedure determines the airplane Basic Empty Weight, moment, and center of gravity in inches aft of datum. C.G. can also be expressed in terms of its location as a percentage of the airplane Mean Aerodynamic Cord (MAC) using the following formula:

$$C.G. \% MAC = 100 \times (C.G. \text{ Inches} - LEMAC) \div MAC$$

Where:

$$LEMAC = 133.1$$

$$MAC = 47.7$$

Center of Gravity Limits

The charts below depict the airplane center-of-gravity envelope in terms of inches aft of the reference datum and as a percentage of the Mean Aerodynamic Cord (MAC). The relationship between the two is detailed in the weighing instructions.

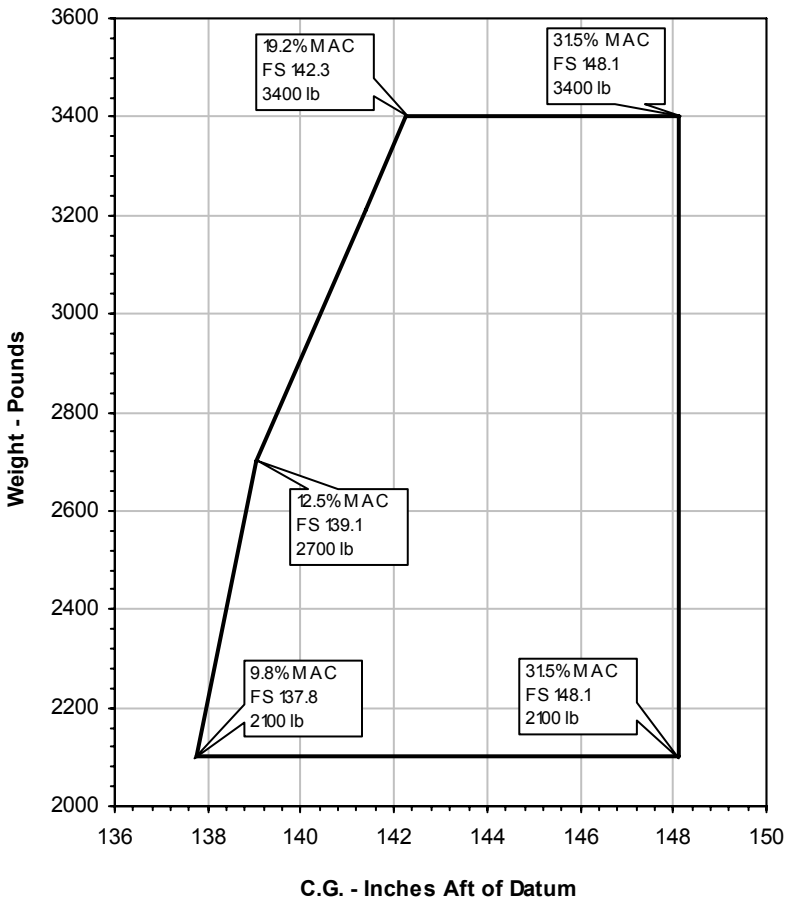

Weight & Balance Loading Form

Serial Num: _____ Date: _____

Reg. Num: _____ Initials: _____

Item	Description	Weight LB	Moment/ 1000
1.	Basic Empty Weight <i>Includes unusable fuel & full oil</i>		
2.	Front Seat Occupants <i>Pilot & Passenger (total)</i>		
3.	Rear Seat Occupants		
4.	Baggage Area <i>130 lb maximum</i>		
5.	Zero Fuel Condition Weight <i>Sub total item 1 thru 4</i>		
6.	Fuel Loading <i>92 Gallon @ 6.0 lb/gal. Maximum</i>		
7.	Ramp Condition Weight <i>Sub total item 5 and 6</i>		
8.	Fuel for start, taxi, and runup <i>Normally 9 lb at average moment of 1394.</i>	-	-
9.	Takeoff Condition Weight <i>Subtract item 8 from item 7</i>		

• Note •

The Takeoff Condition Weight must not exceed 3400 lb.

The Takeoff Condition Moment must be within the Minimum Moment to Maximum Moment range at the Takeoff Condition Weight. (Refer to Moment Limits).

Loading Data

Use the following chart or table to determine the moment/1000 for fuel and payload items to complete the Loading Form.

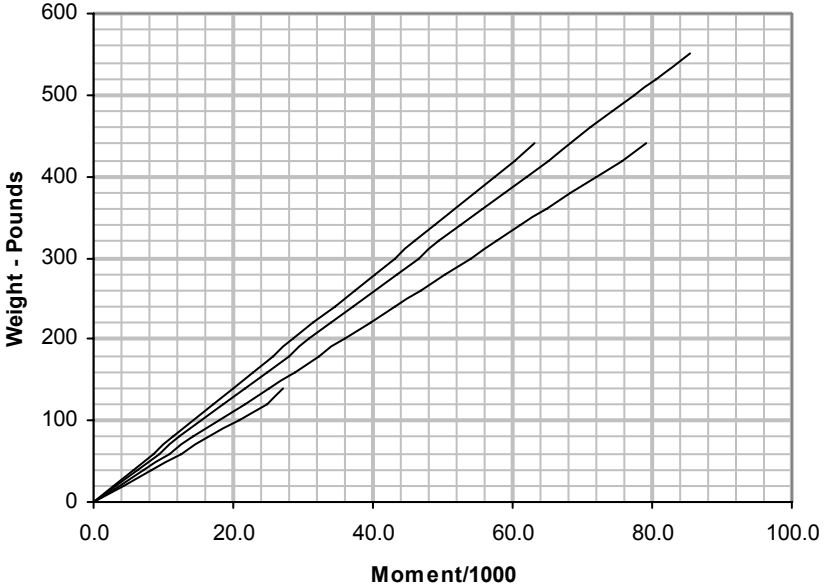

Weight LB	Fwd Pass FS 143.5	Aft Pass FS 180.0	Baggage FS 208.0	Fuel FS 154.9	Weight LB	Fwd Pass FS 143.5	Aft Pass FS 180.0	Fuel FS 154.9
20	2.87	3.6	4.16	3.098	300	43.05	54	46.47
40	5.74	7.2	8.32	6.196	320	45.92	57.6	49.568
60	8.61	10.8	12.48	9.294	340	48.79	61.2	52.666
80	11.48	14.4	16.64	12.392	360	51.66	64.8	55.764
100	14.35	18	20.8	15.49	380	54.53	68.4	58.862
120	17.22	21.6	24.96	18.588	400	57.4	72	61.96
140	20.09	25.2	27.04*	21.686	420	60.27	75.6	65.058
160	22.96	28.8		24.784	440	63.14	79.2	68.156
180	25.83	32.4		27.882	460			71.254
200	28.7	36		30.98	480			74.352
220	31.57	39.6		34.078	500			77.45
240	34.44	43.2		37.176	520			80.548
260	37.31	46.8		40.274	552**			85.5048
280	40.18	50.4		43.372				

*130 lb Maximum

**92 U.S. Gallons Usable

Moment Limits

Use the following chart or table to determine if the weight and moment from the completed Weight and Balance Loading Form (Figure 6-7) are within limits.

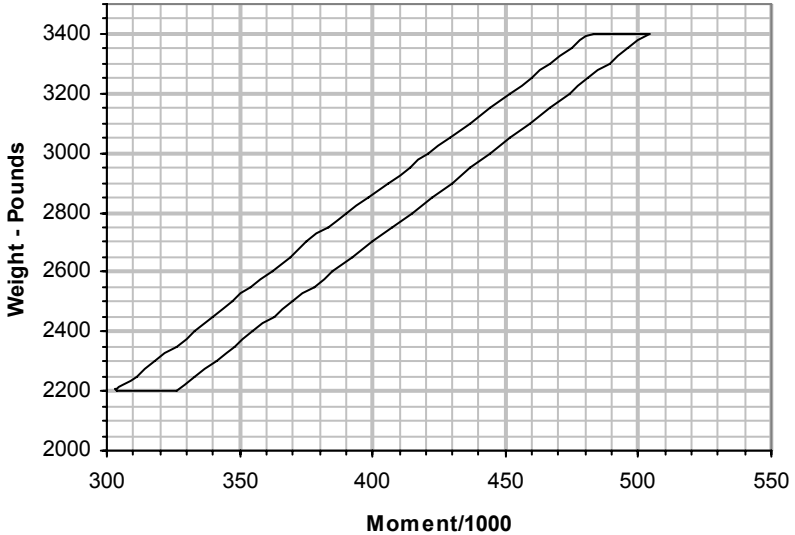

Weight LB	Moment/1000		Weight LB	Moment/1000	
	Minimum	Maximum		Minimum	Maximum
2200	304	326	2850	398	422
2250	311	333	2900	406	430
2300	318	341	2950	414	437
2350	326	348	3000	421	444
2400	333	355	3050	429	452
2450	340	363	3100	437	459
2500	347	370	3150	444	467
2550	354	378	3200	452	474
2600	362	385	3250	460	481
2650	369	392	3300	467	489
2700	375	400	3350	475	496
2750	383	407	3400	483	504
2800	390	415			

Intentionally Left Blank

Section 7 - Systems Description

Airframe

Wings

The wing structure is constructed of composite materials producing wing surfaces that are smooth and seamless. The wing cross section is a blend of several high performance airfoils. A high aspect ratio results in low drag. Each wing provides attach structure for the main landing gear and contains a 47.25-gallon fuel tank.

The G3 Wing is constructed in a conventional spar, rib, and shear section arrangement. The upper and lower skins are bonded to the spar, ribs, and aft shear web forming a torsion box that carries all of the wing bending and torsion loads. The rear shear webs are similar in construction but do not carry through the fuselage. The main spar is laminated epoxy/carbon fiber in a C-section, and is continuous from wing tip to wing tip. The wing spar passes under the fuselage below the two front seats and is attached to the fuselage in two locations. Lift and landing loads are carried by the single carry-through spar, plus a pair of rear shear webs (one on each wing) attached to the fuselage.

Rudder System

G3 Wing geometry is slightly changed with an increase in dihedral of 1° which allows for the elimination of the aileron-rudder interconnect system.

Fuel System

An 92-gallon usable wet-wing fuel storage system provides fuel for engine operation. The system consists of a 47.25-gallon capacity (46-gallon usable) vented integral fuel tank and a fuel collector/sump in each wing, a three position selector valve, an electric boost pump, and an engine-driven fuel pump. Fuel is gravity fed from each tank to the associated collector sumps where the engine-driven fuel pump draws fuel through a filter and selector valve to pressure feed the engine fuel injection system. The electric boost pump is provided for engine priming and vapor suppression.

Each integral wing fuel tank has a filler cap in the upper surface of each wing for fuel servicing. Access panels in the lower surface of each wing allow access to the associated wet compartment (tank) for inspection and maintenance. Float-type fuel quantity sensors in each wing tank supply fuel level information to the fuel quantity indicators. Positive pressure in the tank is maintained through a vent line from each wing tank. Fuel, from each wing tank, gravity feeds through strainers and a flapper valve to the associated collector tank in each wing. Each collector tank/sump incorporates a flush mounted fuel drain and a vent to the associated fuel tank.

The engine-driven fuel pump pulls filtered fuel from the two collector tanks through a three-position (LEFT-RIGHT-OFF) selector valve. The selector valve allows tank selection. From the fuel pump, the fuel is metered to a flow divider, and delivered to the individual cylinders. Excess fuel is returned to the selected tank.

A dual-reading fuel-quantity indicator is located in the center console next to the fuel selector in plain view of the pilot. Fuel shutoff and tank selection is positioned nearby for easy access.

Fuel system venting is essential to system operation. Blockage of the system will result in decreasing fuel flow and eventual engine fuel starvation and stoppage. Venting is accomplished independently from each tank by a vent line leading to a NACA-type vent mounted in an access panel underneath the wing near each wing tip.

The airplane may be serviced to a reduced capacity to permit heavier cabin loadings. This is accomplished by filling each tank to a tab visible below the fuel filler, giving a reduced fuel load of 30.0 gallons usable in each tank (60 gallons total usable in all flight conditions).

Drain valves at the system low points allow draining the system for maintenance and for examination of fuel in the system for contamination and grade. The fuel must be sampled prior to each flight. A sampler cup is provided to drain a small amount of fuel from the wing tank drains, the collector tank drains, and the gascolator drain. If takeoff weight limitations for the next flight permit, the fuel tanks should be filled after each flight to prevent condensation.

Fuel Quantity Indicator

A dual reading 2¼" fuel quantity indicator is installed on the console immediately forward of the fuel selector valve. The LEFT pointer indicates left tank fuel quantity and sweeps a scale marked from 0 to 46 U.S. gallons in 5-gallon increments. The RIGHT pointer sweeps an identical scale for the right tank. Each scale is marked with a yellow arc from 0 to 14 U.S. gallons. The indicators are calibrated to read '0' when no usable fuel remains. Each indicator also provides an output signal to illuminate the FUEL caution light when the fuel quantity goes below approximately 14 gallons in each tank. The fuel quantity indications are derived from float-type fuel-level sensors installed in each main tank. The indicator is internally lighted. 28 VDC for fuel quantity system operation is supplied through the 5-amp FUEL QTY / HOBBS circuit breaker on Main Bus 1.

• Note •

When the fuel tanks are 1/4 full or less, prolonged uncoordinated flight such as slips or skids can uncover the fuel tank outlets. Therefore, if operating with one fuel tank dry or if operating on LEFT or RIGHT tank when 1/4 full or less, do not allow the airplane to remain in uncoordinated flight for periods in excess of 30 seconds.

Fuel Caution Light

The amber FUEL caution light in the annunciator panel comes on to indicate a low fuel condition. The light is illuminated by switches in the fuel quantity indicator if the fuel quantity in both tanks drops below approximately 14 gallons (28 gallons total with tanks balanced in level flight). Since both tanks must be below 14 gallons to illuminate the light, the light could illuminate with as little as 14 gallons in one tank during level flight if the other tank is allowed to run dry. If the FUEL caution light comes on in flight, refer to the Fuel Quantity gages to determine fuel quantity. The light is powered by 28 VDC through the 2-amp ANNUN / ENGINE INST circuit breaker on the Essential Bus.

Exterior Lighting

The airplane is equipped with wing tip navigation lights with integral anti-collision strobe lights and recognition Lights. The landing light is located in the lower cowl.

Recognition Lights

The airplane is equipped with recognition lights on the leading edge of the wing tips. The lights are controlled through the landing light switch on the instrument panel bolster. 28 VDC for recognition light operation is supplied through the 5-amp REC/INST LTS circuit breaker on Main Bus 1.

Environmental System

Cabin heating and ventilation is accomplished by supplying conditioned air for heating and windshield defrost and fresh air for ventilation. The environmental system consists of a fresh air inlet in the lower RH cowl, a heat exchanger around the RH engine exhaust muffler, an air mixing chamber, air ducting for distribution, a distribution manifold, a windshield diffuser, and crew and passenger air vents. An optional 3-speed blower fan is available to supplement airflow when ram air may be inadequate such as during ground operation.

Fresh air enters the cabin air distribution system through a NACA vent on the RH lower cowl and is ducted to the air mixing chamber mounted to the forward side of the firewall. Fresh air also enters the upper RH cowl inlet, flows through the upper cowl, and is ducted to a heat exchanger surrounding the RH engine exhaust muffler. The heated air is then routed to the air mixing chamber to be mixed with the fresh air. The mixed air is then distributed by either ram air or by optional blower fan to the distribution manifold mounted to the center, aft side of the firewall. The distribution manifold uses butterfly valves to control airflow to the floor and defrost vents. Airflow is ducted directly to all panel air vents.

The crew panel air vents are chest high outlets mounted in the RH and LH bolster panels. The crew floor air vents are mounted to the bottom of each kick plate. The passenger panel air vents are chest high outlets mounted in the armrests integral to the LH and RH cabin wall trim panels. The passenger floor air vents are mounted to the bottom portion of the LH and RH cabin wall trim panels. The windshield diffuser, located in the glareshield assembly, directs conditioned air to the base of the windshield. Temperature, volume, and flow selection are regulated by manipulation of the cabin airflow, cabin vents, and cabin temperature selector knobs on the lower RH side of the instrument panel. The optional blower fan is powered by 28 VDC supplied through 15-amp Fan breaker on Main A/C Bus 2.

For the optional air conditioning system, refer to the Air Conditioning System Pilot's Operating Handbook Supplement, P/N 13772-127, Revision 1 or later, for a complete description of the system, its operating modes, and additional detailed operating procedures.

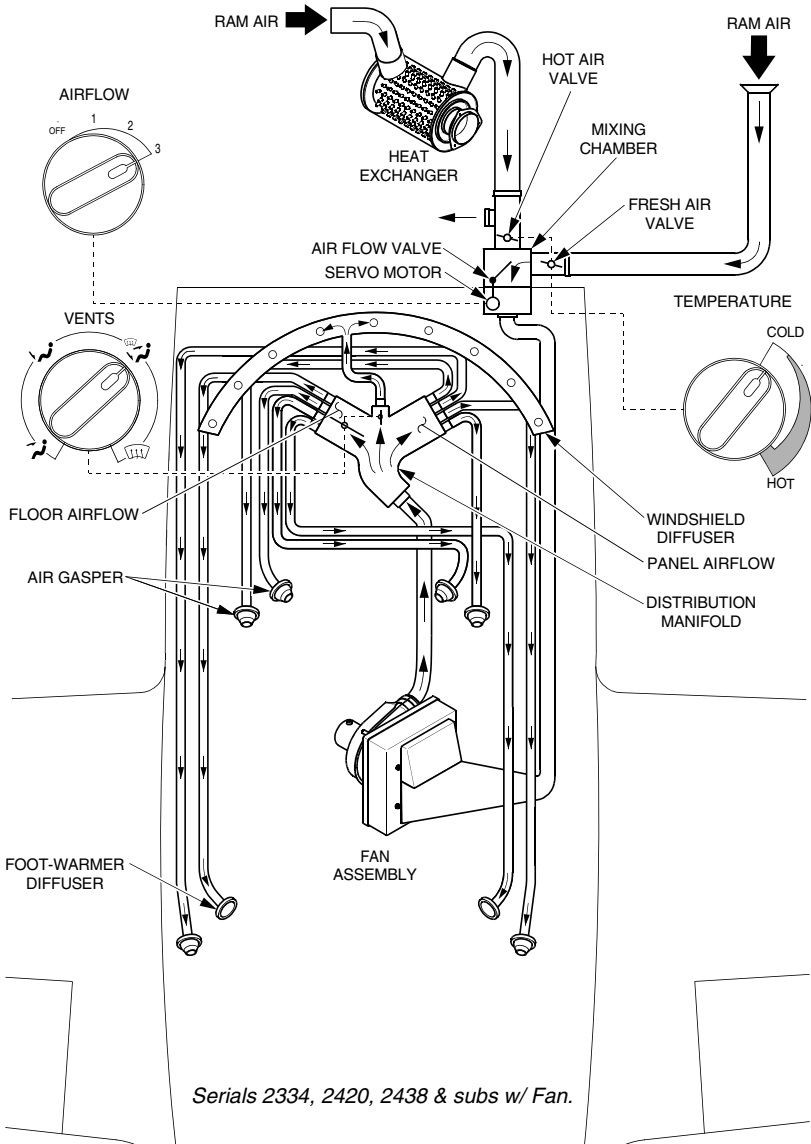

NOTE: Illustration depicts maximum cabin cooling airflows and selector settings.

SR22_FM09_2588

Figure - 6
Environmental System

Airflow Selection

The airflow selector on the system control panel regulates the volume of airflow allowed into the cabin distribution system. When the airflow selector is moved to the ON position an electro-mechanical linkage actuates a butterfly valve in the mixing chamber on the forward firewall to the full open position. The air is then distributed by either ram air or by an optional blower fan to the distribution manifold mounted to the center, aft side of the firewall

Vent Selection

Conditioned air from the distribution manifold can be proportioned and directed to passengers and/or the windshield by manipulating the cabin vent selector. The selector is mechanically linked to butterfly valves at the entrances to the windshield diffuser and the cabin floor ducting. There is continuous airflow to the panel and armrest eyeball outlets. Each occupant can control the flow rate from 'off' to maximum by rotating the nozzle.

When the selector is in the far left position, both butterfly valves are closed providing maximum airflow to the panel and armrest eyeball outlets. Rotating the selector a quarter-turn clockwise opens the cabin floor butterfly valve allowing airflow to the rear seat foot warmer diffusers and the front seat outlets mounted to the underside of each kickplate. Rotating the selector another quarter-turn clockwise opens the windshield diffuser butterfly valve which permits shared airflow to the defrosting mechanism and cabin floor outlets. When the selector is in the far right position, the cabin floor butterfly valve is closed providing maximum airflow to the windshield diffuser.

Temperature Selection

The temperature selector is mechanically linked to the hot and cold air valves. Rotating the selector simultaneously opens and closes the two valves, permitting hot and cold air to mix and enter the distribution system. Rotating the selector clockwise, permits warmer air to enter the system - counterclockwise, cooler air.

Section 8 - Handling, Servicing & Maintenance

Servicing

Filling Fuel Tanks

Observe all safety precautions required when handling gasoline. Fuel fillers are located on the forward slope of the wing. Each wing holds a maximum of 46.0 U.S. gallons. When using less than the standard 92.0 U.S. gallon capacity, fuel should be distributed equally between each side.

Intentionally Left Blank